

# DuraFLEX 2 - Step

The most durable seamless soft seating. Perfect for high traffic spaces like schools, libraries, healthcare, museums, retail, and more. Non-porous and waterproof flexible plastic shell with a flexible foam core. A solid base with fixed legs and the option for caster wheels for mobility. No hidden pockets or stitched seams where bacteria can hide and multiply. Surface can be readily washed and disinfected. Indoor use. Compliant with CAL133 Fire Testing and labeled accordingly. "MAS Certified Green" for healthier indoor air quality. Global Educator Institute (GEI) Endorsed.

### With 1" Height Fixed Legs:

Item # 15022B1\_ : 2-Step DuraFLEX, 32" Height, 200 lbs

Item # 15023B1\_ : 3-Step DuraFLEX, 32" Height, 200 lbs

### With 1.75" Caster Wheels w/Brakes:

Item # 15022BC\_ : 2-Step DuraFLEX, 32.75" Height, 202 lbs

Item # 15023BC\_ : 3-Step DuraFLEX, 32.75" Height, 202 lbs

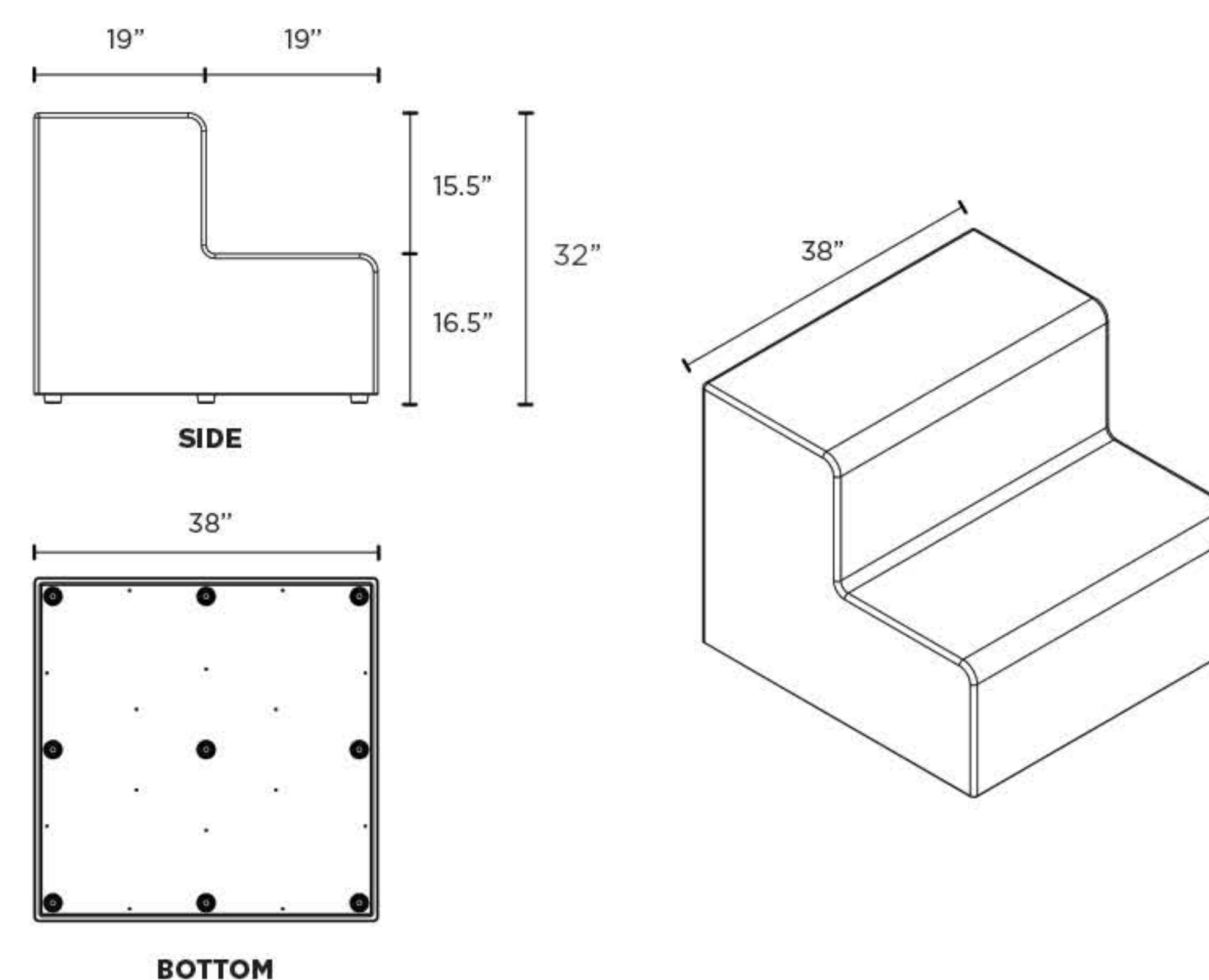

### DuraFlex Standard Colors

<b>Orange</b> Color Code: OR	<b>Red</b> Color Code: RD	<b>Maroon</b> Color Code: MA	<b>Violet</b> Color Code: VI	<b>Dark Purple</b> Color Code: DP	<b>Dark Blue</b> Color Code: DB
<b>Medium Blue</b> Color Code: MB	<b>Anthracite Grey</b> Color Code: AG	<b>Dark Green</b> Color Code: DG	<b>Pure Green</b> Color Code: PG	<b>Lime Green</b> Color Code: LM	<b>Medium Grey</b> Color Code: MG